

A	B	C
8 cm	7,5 cm	6 cm

- A** *Évacuation des fumées*
- B** *Sortie de la canalisation*
- C** *Conduit d'air comburant*

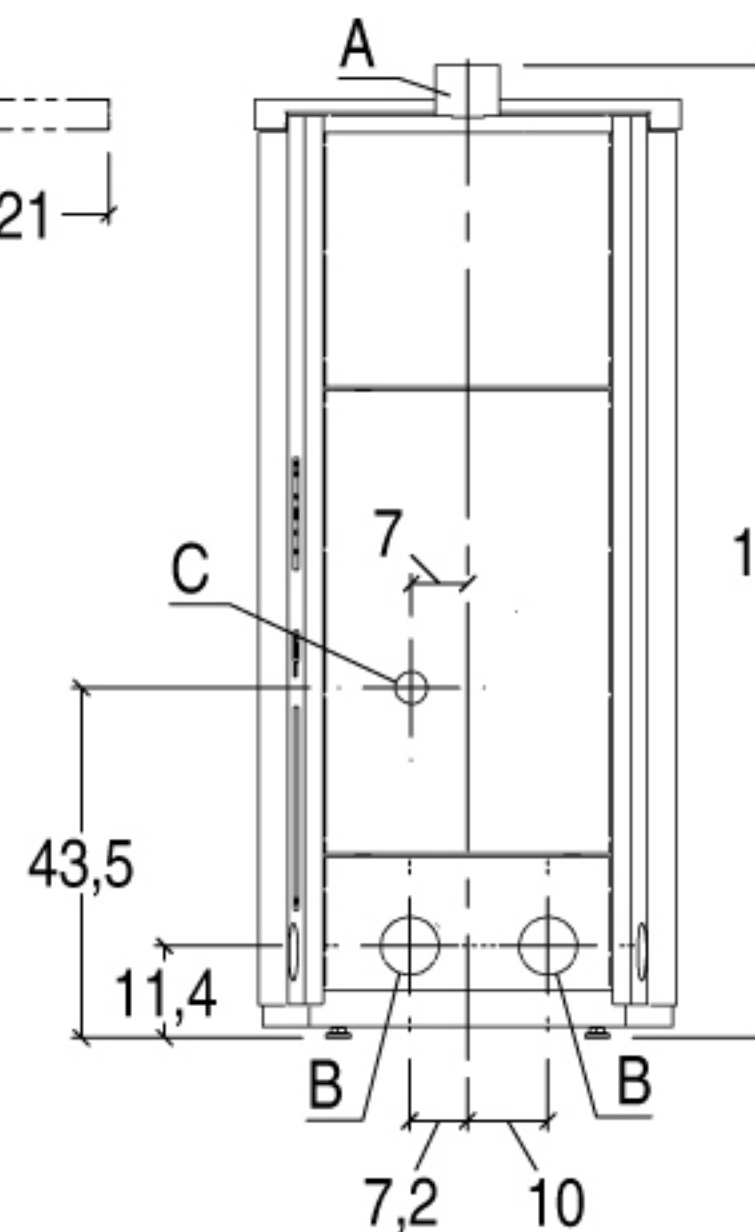
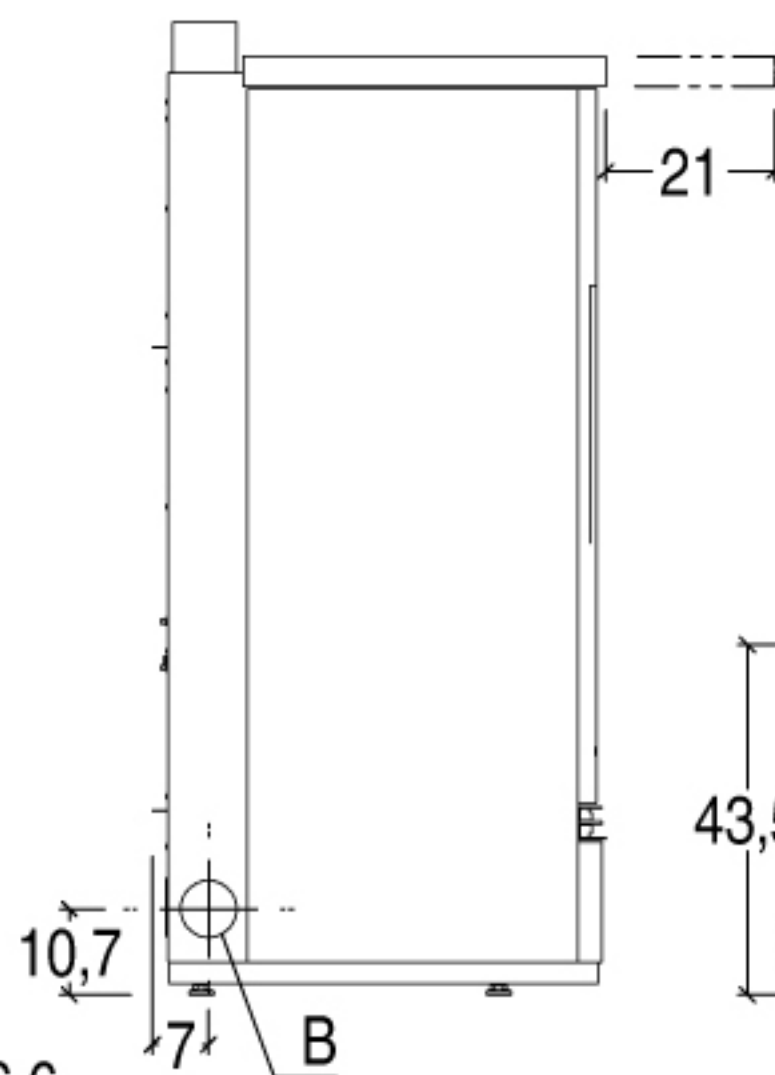
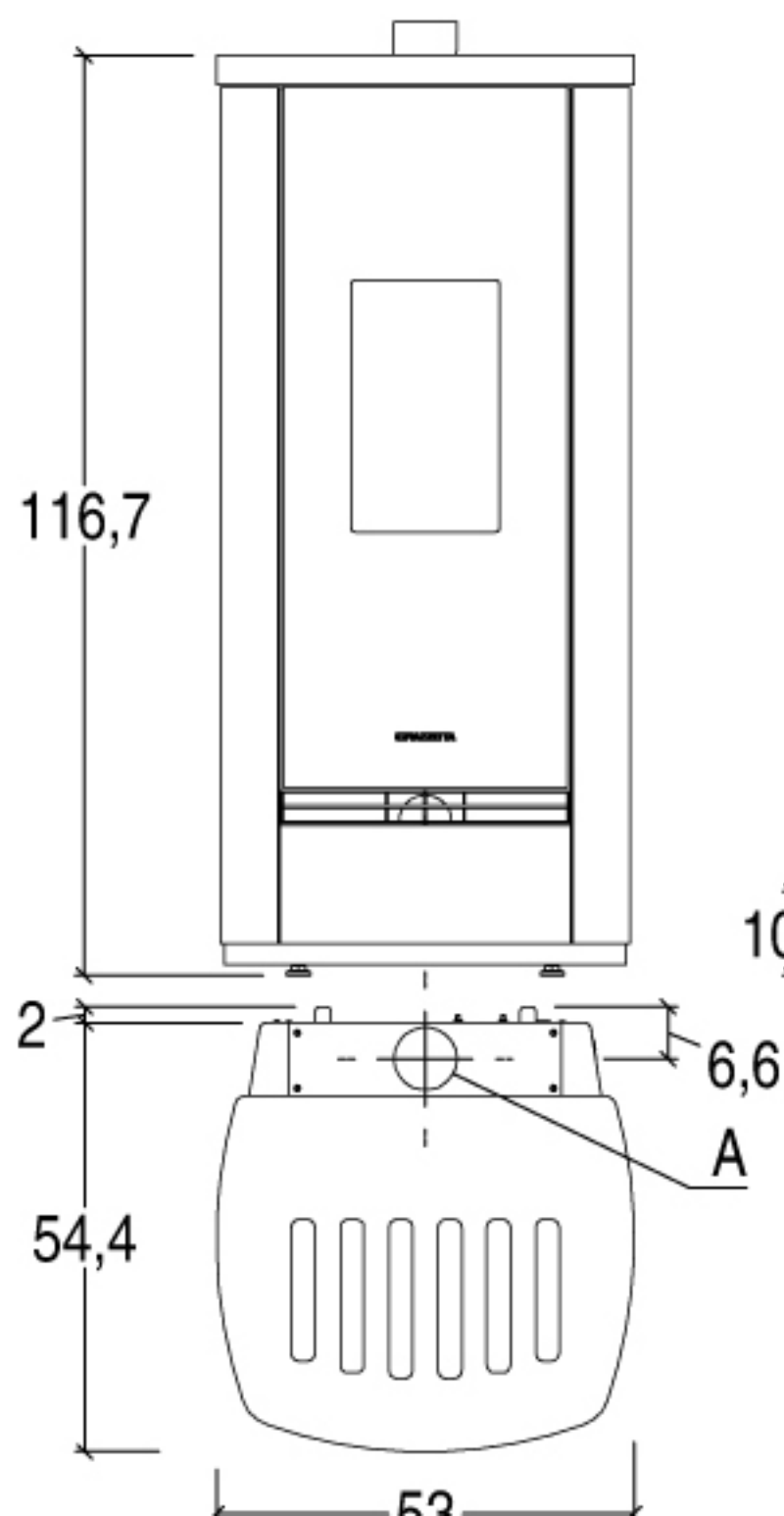
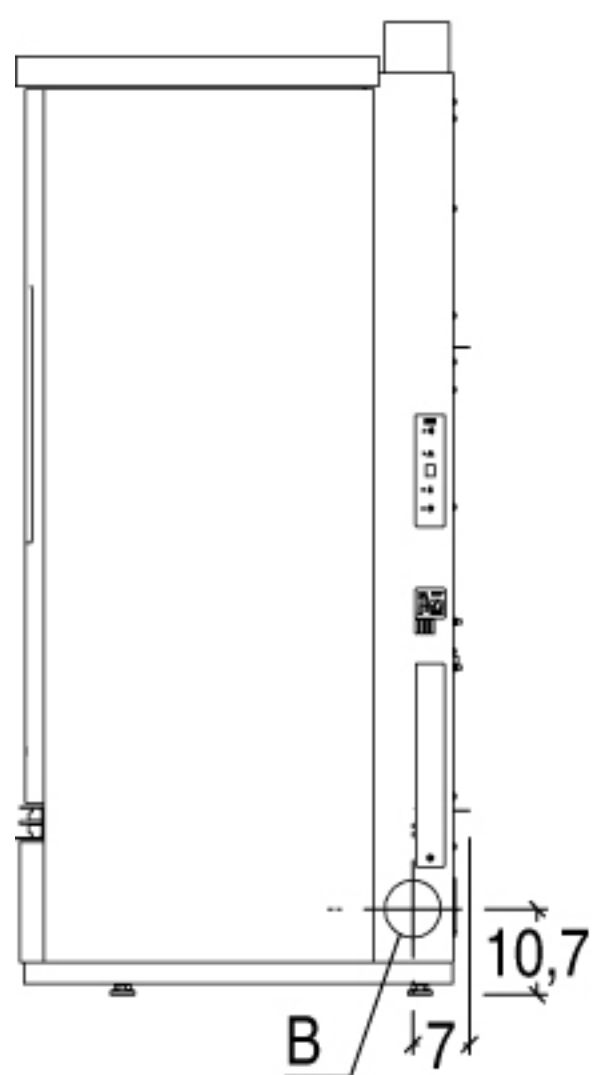

A	B	C
8 cm	7,5 cm	6 cm

- A** *Évacuation des fumées*
- B** *Sortie de la canalisation*